

C4-TOP

Manual (3.0E)

References in the manual

WARNING!

This refers to a potentially dangerous situation which may lead to personal injury.

CAUTION!

This refers to a potentially dangerous situation which may lead to damage to the equipment.

IMPORTANT!

This refers to a situation which may cause the equipment to malfunction.

Symbols on the equipment



Please refer to the information in the operating manual.



WARNING!
Dangerous voltage!

General Information

C4-TOP Loudspeaker Manual

Version 3.0E, 10/2003, D2074.E.03

© by d&b audiotechnik AG 2003; all rights reserved.

The information contained in this manual has been carefully checked for accuracy, at the time of going to press, however no guarantee is given with respect to the correctness.

d&b audiotechnik AG accepts no responsibility for any errors or inaccuracies that may appear in this manual or the products and software described in it.

Technical specifications, dimensions, weights and properties do not represent guaranteed qualities.

As manufacturers we reserve the right to make alterations and modifications within the framework of legal provisions, as well as changes aimed at improving quality.

d&b audiotechnik AG

Eugen-Adolff-Strasse 134, D-71522 Backnang, Germany

Telephone +49-7191-9669-0, Fax +49-7191-95 00 00

E-mail: docadmin@dbaudio.com, Internet: www.dbaudio.com

Safety precautions

Before you use our products, read the manual carefully and observe all the safety precautions. They will protect you and help to avoid equipment failures.

Keep this manual in a safe place so that it is available for future reference.

If you supply d&b products, please draw the attention of your customers to these safety guidelines. Enclose the relevant manuals with the systems. If you require additional manuals for this purpose, you can order them from d&b.

Information regarding use of loudspeakers

WARNING!

Never stand in the immediate vicinity of loudspeakers driven at a high level. Professional loudspeaker systems are capable of causing a sound pressure level detrimental to human health. Seemingly non-critical sound levels (from approx. 95 dB SPL) can cause hearing damage if people are exposed to it over a long period.

In order to prevent accidents when deploying loudspeakers on the ground or when flown, please take note of the following:

When setting up the loudspeakers or loudspeaker stands, make sure they are standing on a firm surface. If you place several systems on top of one another, use straps to secure them against movement.

Only use accessories which have been tested and approved by d&b for assembly and mobile deployment. Pay attention to the correct application and maximum load capacity of the accessories as detailed in our specific "Mounting instructions" or in our "Flying system and Rigging manuals".

Ensure that all additional hardware, fixings and fasteners used for installation or mobile deployment are of an appropriate size and load safety factor. Pay attention to the manufacturers instructions and to the relevant safety guidelines.

Regularly check the loudspeaker housings and accessories for visible signs of wear and tear, and replace them when necessary.

Regularly check all load bearing bolts in the mounting devices.

CAUTION!

Loudspeakers produce a static magnetic field even if they are not connected or are not in use. Therefore make sure when erecting and transporting loudspeakers that they are nowhere near equipment and objects which may be impaired or damaged by an external magnetic field. Generally speaking, a distance of 0.5 m (1.5 ft) from magnetic data carriers (floppy disks, audio and video tapes, bank cards, etc.) is sufficient; a distance of more than 1 m (3 ft) may be necessary with computer and video monitors.

C4-TOP

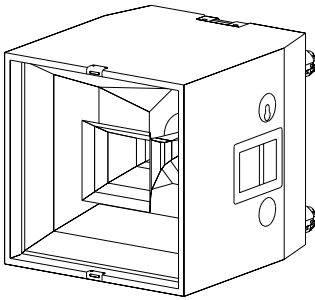

The C4-TOP is a two-way hornloaded loudspeaker which provides high SPL coverage from mid to high frequencies. The constant directivity design of the C4-TOP's coaxial horns ensures that its 35° x 35° dispersion is maintained down to 700 Hz. The driver complement consists of two passively coupled devices - a 12" low/mid frequency driver and a 2" HF compression driver.

The C4-TOP cabinet is constructed from marine plywood and has an impact resistant paint finish. The front of the loudspeaker cabinet is fitted with a rigid metal grill covered with a replaceable acoustically transparent foam, and fitted with catches to the top and bottom for securing an optional transport lid E7908. The cabinet incorporates two steel handles and MAN CF4 stud plate rigging points. Mounted on the rear panel are ratchet strap guide plates (kelping bars) and four heavy duty wheels.

CAUTION!

Only operate C4-TOP cabinets with a d&b D12 or E-PAC amplifier in C4-TOP mode or a P1200A mainframe fitted with a C4-TOP controller module, otherwise there is a risk of damaging the loudspeaker components.

Connections

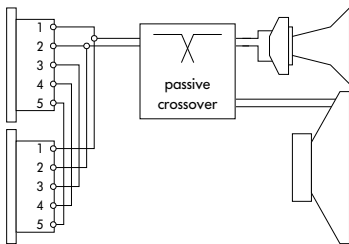

Connector wiring

The C4-TOP cabinet is fitted with a pair of EP5 connectors. All pins of both connectors are wired in parallel. The C4-TOP uses the pin assignments 1/2. Pins 3/4 and 5 are designated to d&b active subwoofers.

Using one connector as the input, the second connector allows for direct connection to additional cabinets.

The C4-TOP can be supplied with NL4 output connectors as an option using the pin assignment 1+/1-. Pins 2+/2- are designated to d&b active subwoofers.

Pin equivalents of EP5 and NL4 connectors are listed in the table below.

EP5	1	2	3	4	5 (SenseDrive SUB)
NL4	1+	1-	2+	2-	n.c.

EP5 and NL4 pin assignments

Operation with D12

Selecting C4-TOP mode in the D12 enables up to two C4-TOP cabinets to be driven by each channel. In applications with low continuous levels and low ambient temperatures up to three cabinets per channel may be connected.

When the D12 is operated in "Mix TOP/SUB" mode configuration the C4-TOP cabinet and a respective active subwoofer can be linked together locally and fed by a single 4-wire cable from either amplifier output connector.

To apply SenseDrive for the subwoofer, EP5 connectors and 5-wire cables have to be used. When operated in "Mix TOP/SUB" mode the subwoofer has to be fed from the output B connector of the D12 amplifier.

IMPORTANT!

Controller settings

For acoustic adjustment the settings HFC and CPL can be selected.

HFC circuit

In HFC mode (High Frequency Compensation), the response of the system is tailored for remote listening positions. The characteristics of HFC mode is shown in the diagram opposite.

Selecting HFC compensates for loss of high frequency energy due to absorption in air when loudspeakers are used to cover far field listening positions. The HFC correction equates to the HF loss which occurs at a distance of 30 m (100 ft) at 20°C (68°F) in 50 % relative humidity.

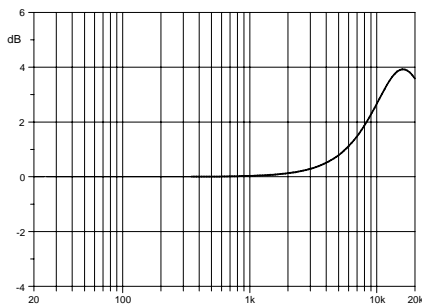

Frequency response of HFC circuit

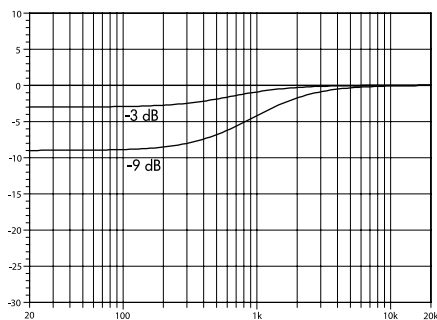

Frequency response of CPL circuit

CPL circuit

The CPL (Coupling) circuit compensates for coupling effects between the cabinets when building closely coupled arrays. CPL begins gradually at 1 kHz, with maximum attenuation below 250 Hz, providing a balanced frequency response when C4-TOP cabinets are used in arrays of two or more. The function of the CPL circuit in the D12 amplifier is shown in the diagram opposite and can be set in dB attenuation values between -9 and 0.

Operation with E-PAC (Version 3 with display only)

Selecting C4-TOP mode in the E-PAC enables one C4-TOP cabinet to be driven at an output power of 300 Watts. LO IMP mode allows the E-PAC to drive two C4-TOP cabinets with a 6 dB reduction of input level to the loudspeakers.

The HFC setting is available. The characteristics of the HFC setting is explained under the previous section "Operation with D12 - Controller settings".

Operation with P1200A

Up to two C4-TOP cabinets can be driven by each P1200A power amplifier channel. Fitting one C4-TOP and one subwoofer controller module allows a single mainframe to drive two C4-TOPs and two active subwoofer cabinets. All cabinets can be linked together locally and fed by a single 4-wire cable from either mainframe output connector.

The HFC setting is available. The characteristics of the HFC setting is explained under the previous section "Operation with D12 - Controller settings".

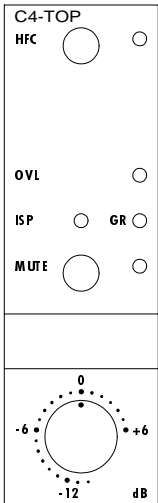

Controls on C4-TOP controller module

Dispersion characteristics

The diagram below show dispersion angle vs frequency plotted using lines of equal sound pressure (isobars) at -6 dB and -12 dB. The nominal 35° dispersion is maintained from 16 kHz down to 700 Hz. Horizontal and vertical characteristics are identical.

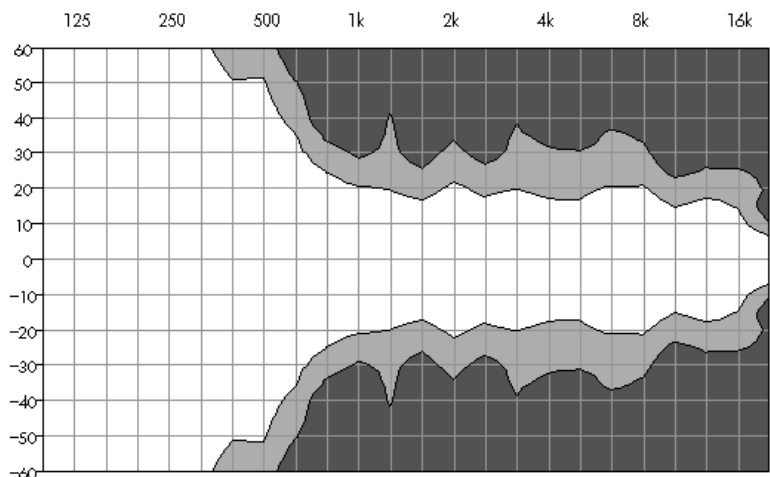

C4-TOP isobar diagram

Technical specifications

C4-TOP system data

Frequency response (-5 dB).....150 Hz - 18 kHz
 Max. sound pressure (1 m, free field) with D12 140 dB
 Max. sound pressure (1 m, free field) with E-PAC 136 dB
 Max. sound pressure (1 m, free field) with P1200A 138 dB
 (SPLmax peak, pink noise test signal with crest factor of 4)
 Input level (SPLmax)..... +14 dBu
 Input level (100 dB SPL / 1 m)..... -21 dBu
 Polarity to controller INPUT (XLR pin 2: + / 3: -) LF: + / HF: +

C4-TOP loudspeaker

Nominal impedance..... 8 ohms
 Power handling capacity (RMS / peak 10 ms)..... 200 / 800 W
 Nominal dispersion angle (hor. x vert.)..... 35° x 35°
 Connections 2 x EP5
 Pin assignments 1/2
 optional..... 2 x NL4
 Pin assignments 1+ / 1-
 Weight 58 kg (128 lb)

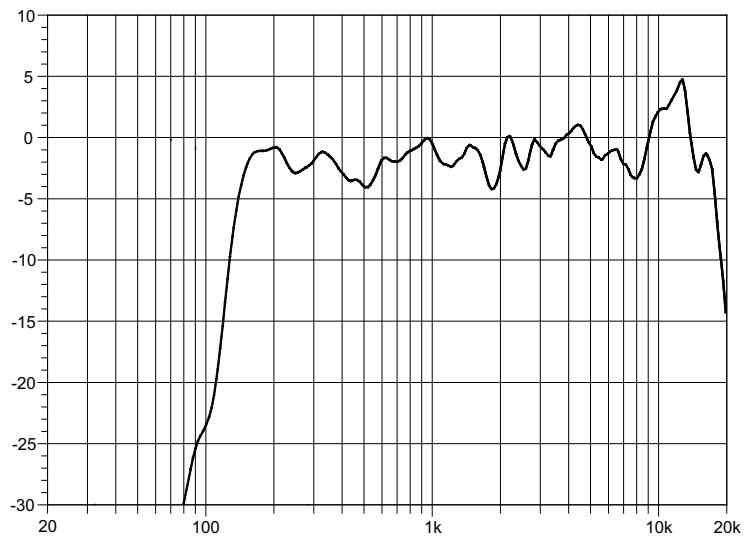

C4-TOP frequency response

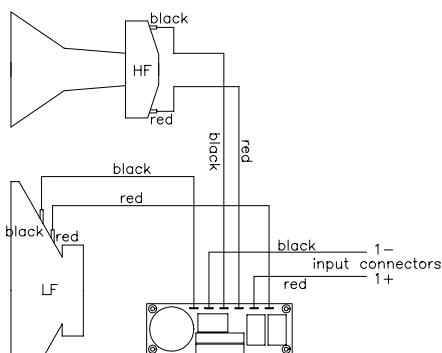

C4-TOP wiring diagram

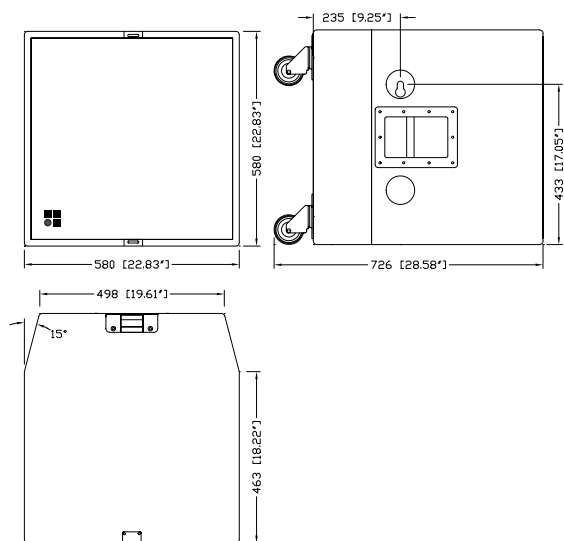

C4-TOP cabinet dimensions in mm [inch]

EU declaration of conformity (CE symbol)



EU conformity of loudspeakers

This declaration applies to loudspeakers manufactured by d&b audiotechnik AG and includes the types listed in the table below:

– **C4-TOP Z2254**

All production versions of these types are included, provided they correspond to the original technical version and have not been subject to any later design or electromechanical modifications.

We herewith declare that said products are in conformity with the provisions of the following EC directives including all applicable amendments:

– **89/336 Electromagnetic Compatibility**

The following standards have been applied:

- **DIN EN 55013:08-1991**
- **DIN EN 55020:05-1995**
- **DIN EN 50082-1:03-1993**